

OVERHEAD SWITCHES HOOKSTICK-OPERATED

Warranty - Material

Hubbell Power Systems, Inc. warrants all products sold by it to be merchantable (as such term is defined in the Uniform Commercial Code) and to be free from defects in material and workmanship. Buyer must notify the Company promptly of any claim under this warranty. The Buyer's exclusive remedy for breach of this warranty shall be the repair or replacement, F.O.B. factory, at the Company's option, of any product defective under the warranty which is returned to the Company within one year from the date of shipment. NO OTHER WARRANTY, WHETHER EXPRESS OR ARISING BY OPERATION OF LAW, COURSE OF DEALING, USAGE OF TRADE OR OTHERWISE IMPLIED, SHALL EXIST IN CONNECTION WITH THE COMPANY'S PRODUCTS OR ANY SALE OR USE THEREOF. The Company shall in no event be liable for any loss of profits or any consequential or special damages incurred by Buyer. The Company's warranty shall run only to the first Buyer of a product from the Company, from the Company's distributor, or from an original equipment manufacturer reselling the Company's product, and is non-assignable and non-transferable and shall be of no force and effect if asserted by any person other than such first Buyer. This warranty applies only to the use of the product as intended by Seller and does not cover any misapplication or misuse of said product.

Warranty - Application

Hubbell Power Systems, Inc. does not warrant the accuracy of and results from product or system performance recommendations resulting from any engineering analysis or study. This applies regardless of whether a charge is made for the recommendation, or if it is provided free of charge.

Responsibility for selection of the proper product or application rests solely with the purchaser. In the event of errors or inaccuracies determined to be caused by Hubbell Power Systems, Inc., its liability will be limited to the re-performance of any such analysis or study.

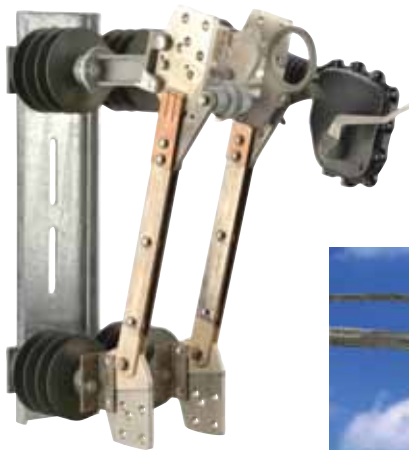

NOTICE: For latest revision of our Catalog and Literature, please visit our web site: www.hubbellpowersystems.com

NOTE: Because Hubbell has a policy of continuous product improvement, we reserve the right to change design and specifications without notice.

©Copyright 2010 Hubbell Incorporated • 210 North Allen Street • Centralia, MO 65240 USA
www.hubbellpowersystems.com
E-mail: hpsliterature@hps.hubbell.com

Type M3 Hookstick Disconnect Switches

Up to 38kV 600 or 900 Amp 40kA Momentary

Application

The Chance Type M3 Disconnect Switch is a single-phase hookstick operated switch. It is for manual switching of overhead lines on electrical distribution systems up to 38kV. Design variations allow for applications as a distribution switch or a substation switch. Rated for 600 or 900 amps continuous, 40,000 amps momentary and 25,000 amps sym. 2-second short-time withstand, the M3 may be applied on:

- Dip/Riser poles
- Single crossarm
- Double crossarm
- Aluminum or steel structure

and wherever a disconnect switch is desirable for line sectionalizing. The addition of optional bypass studs allows for

bypassing reclosers, regulators, capacitor banks or metering devices.

Operation

All Chance M3 disconnect switches include loadbreak hooks which serve both as a blade closing guide and for use with a portable loadbreak tool. To open the switch under load, use only an approved loadbreak tool and refer to the tool manufacturer for instructions.

Positive latching is provided. Silver-plating on the contact areas enhances efficient current transfer. For easy opening and ice-breaking action, the pull ring activates the latch as a pry-out lever.

Components of the M3 Switch

1. By-pass Studs (Optional)

Two copper alloy by-pass studs used for regulator, reclosers, and metering devices for by-passing operations. Provides superior corrosion protection as well as high conductivity. Chance hot line clamps are to be used in conjunction with this option (refer to section 13 of the Chance catalog for selection of proper clamp).

2. Terminal Pad (Standard)

High conductivity tin-plated copper, NEMA two-hole terminal pad.

3. Back-up Springs (Standard)

Two stainless steel springs (300 series) for high strength and superior corrosion resistance to maintain efficient current transfer at the stationary contact and end of blade.

4. Loadbreak Hooks (Standard)

Hot dipped galvanized steel to ASTM A153 for corrosion protection to be used with portable loadbreak tool. Also acts as a blade guide to increase the side loading capabilities during switch closing.

5. Copper Blade (Standard)

High conductivity copper blade and silver-plated moving contact areas. The blade utilizes four-finger contact design for superior performance on momentary currents. Blade is triangulated and edge-formed for superior stiffness and blade side-loading capability during closing.

6. Stainless steel pin (Standard)

Stainless steel pin can be positioned to stop the blade at 90° (as supplied) or 160°.

7. 160° Open Position Latch (Optional)

This is a 300 series stainless steel latch to hold the blade in the 160° open position.

8. Parallel Groove Connectors, (Optional)

Catalog No. ATC1343, fortified cadmium-plated aluminum parallel groove clamp, furnished with galvanized steel bolts and nuts and will accept #2 through 500 kemil aluminum or copper conductor.

9. Insulators

Available in 2.25-inch bolt circle distribution insulators of light weight ESP™ silicon alloy rubber or porcelain.

10. Switch Base

Bases are hot dip galvanized to ASTM A153 for corrosion protection and can be mounted with the supplied back-strap on a single or double crossarm; they can also be mounted on aluminum or steel equipment mounts. See drawings on following pages for dimensions.

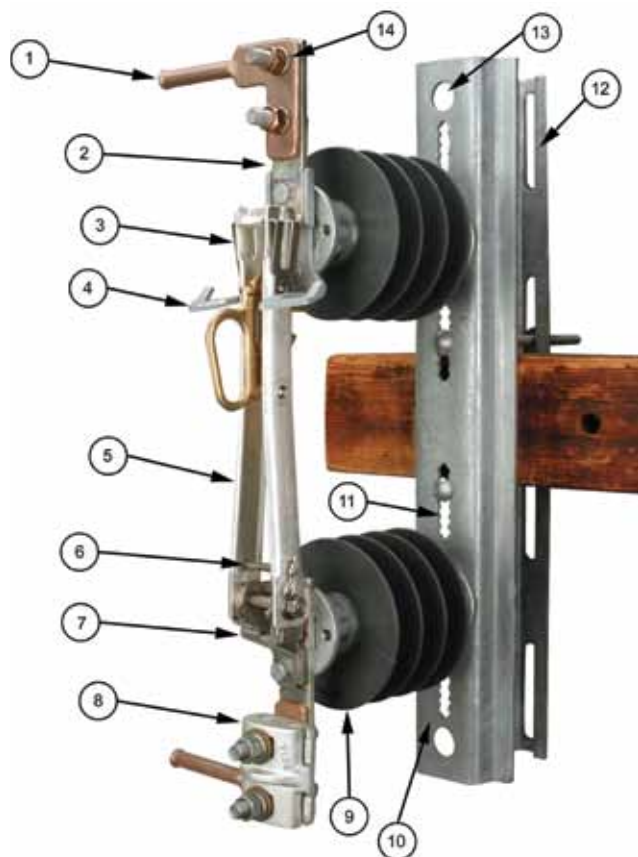

11. Serrated Slots (Standard)

For retaining 3/8" carriage bolts, which are included, with the mounting back-strap when ordered. Smooth slots are available as an option. (Distribution switches only)

12. Back-strap (Standard)

Comes with hardware to match the distribution base ordered: U-shaped for rigidity and strength. Galvanized to ASTM A153 for corrosion protection. (Distribution switches only)

13. Dead-end Provision (Standard)

Holes for dead-ending conductors are stamped out of the galvanized steel base. Rated for 8,000 lb. working load. Hole size is 1"

14. Captive Hardware (Optional)

Two stainless steel spline bolts pressed into each terminal pad, bronze nut and stainless steel lock washer included.

DISTRIBUTION CLASS (2.25" Bolt-Circle) Switch Ratings

| Max. kV | Rated BIL* | Material | Switch Electrical Ratings | | | | Insulator Mechanical Ratings | | | | |
|---------|------------|------------|---------------------------|--------------------------|-----------------------|-----|------------------------------|-----------------|------------------|---------------------|-------------|
| | | | Leakage Distance, inches | Dry Arc Distance, inches | 60 Hz Flash-over, kV* | | Cantilever, pounds | Tension, pounds | Torsion, in.-lb. | Compression, pounds | Weight, lb. |
| | | | | | Wet | Dry | | | | | |
| 15.5 | 110 | ESP Rubber | 17.2 | 7.1 | 30 | 38 | 1,200 | 5,000 | 3,000 | 5,000 | 2.90 |
| | | Porcelain | 10.5 | 6.0 | 30 | 38 | 1,200 | 5,000 | 3,000 | 5,000 | 7.73 |
| 27 | 125 | ESP Rubber | 21.9 | 8.1 | 45 | 50 | 1,000 | 5,000 | 3,000 | 5,000 | 3.30 |
| | | Porcelain | 15.5 | 7.0 | 45 | 50 | 1,000 | 5,000 | 3,000 | 5,000 | 9.00 |
| 38 | 150 | ESP Rubber | 28 | 10.0 | 60 | 70 | 800 | 5,000 | 3,000 | 5,000 | 4.50 |
| | | Porcelain | 24.0 | 9.5 | 60 | 70 | 800 | 5,000 | 3,000 | 5,000 | 11.45 |

*ANSI Rating. Less than test results. Test reports available upon request.

Distribution Class Ratings

Nominal Voltage/BIL: 14.4kV/110kV, 25kV/125kV, 34.5/150kV
Continuous Current: 600 or 900 amp
Momentary Current: 40,000 amperes asymmetrical
Short Time Withstand Current 2-sec.: 25,000 amperes sym.
Deadending: 8,000 lb. working load

DISTRIBUTION Class Insulators

Distribution class insulators are 2³/₄" bolt-circle, provided with 110, 125 or 150kV BIL respectively for the 15.5, 27 and 38kV ratings. These are available in either ESP™ silicon alloy rubber or porcelain insulators.

ESP™ Insulator, available in three sizes

Structural design of ESP™ insulator:
• Rod

ESP™ insulator fiberglass rod is produced from the highest quality material. Strands are aligned for the maximum tensile strength. The rod is filled with electrical grade glass fibers.

• End Fittings

Ductile iron castings are mechanically crimped directly to the fiberglass rod. The crimp requires no intermovement of the parts to achieve high strength, nor does it introduce potting compounds or adhesives.

• Weathersheds

ESP™ insulators are the same proven material used in PDV arresters, Hi*Lite and Veri*Lite insulators and PDI dead-ends. ESP™ is a polymer compound made by alloying silicone and EPDM rubber. This alloy offers the desirable toughness and resistance to tracking of Ohio Brass's original EPR, with the hydrophobic characteristics derived from low molecular weight silicone oils.

Ohio Brass uses several tests to evaluate materials. Tracking, QUV, corona cutting, salt fog, oxidative stability and variations of differential thermal analysis tests assure the quality of OB's shed material. For further information on our polymers ask your Hubbell representative for the publication "Polymer Materials for Insulator Weathersheds" EU1264-H.

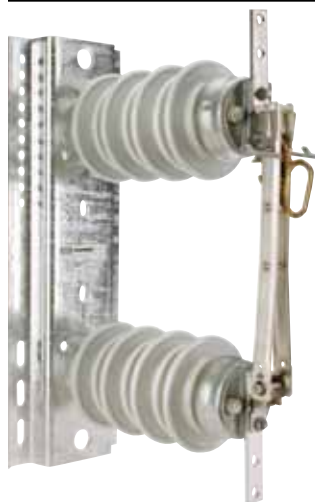
STATION CLASS (3" Bolt-Circle) Switch Ratings

| Rated BIL* | Material | Electrical | | | | Mechanical | | | |
|------------|-----------|--------------------------|--------------------------|-----------------------|-----|--------------------|-----------------|------------------|---------------------|
| | | Leakage Distance, inches | Dry Arc Distance, inches | 60 Hz Flash-over, kV* | | Cantilever, pounds | Tension, pounds | Torsion, in.-lb. | Compression, pounds |
| | | | | Wet | Dry | | | | |
| 110 | Polymer | 19.0 | 8.0 | 45 | 50 | 2,000 | 8,500 | 7,000 | 10,000 |
| | Porcelain | 15.5 | 7.0 | 45 | 50 | 2,000 | 8,500 | 7,000 | 10,000 |
| 150 | Porcelain | 24.0 | 9.5 | 60 | 70 | 2,000 | 10,000 | 8,000 | 10,000 |

*ANSI Rating. Less than test results. Test reports available upon request.

STATION Class Insulators

Station class insulators are available with Sky-Glaze horizon-blending 3" bolt-circle, which provide 110 and 150kV BIL respectively for the 15 and 27kV substation switches. These are available in porcelain or at 15kV polymer (cycloaliphatic).

Substation-style Station Class Type M3S switch is made for mounting on a steel structure or on a pole-mounted aluminum or steel equipment mount.

DISTRIBUTION CLASS M3 SWITCH—DIMENSIONAL DATA 110kV BIL - 600 Amp

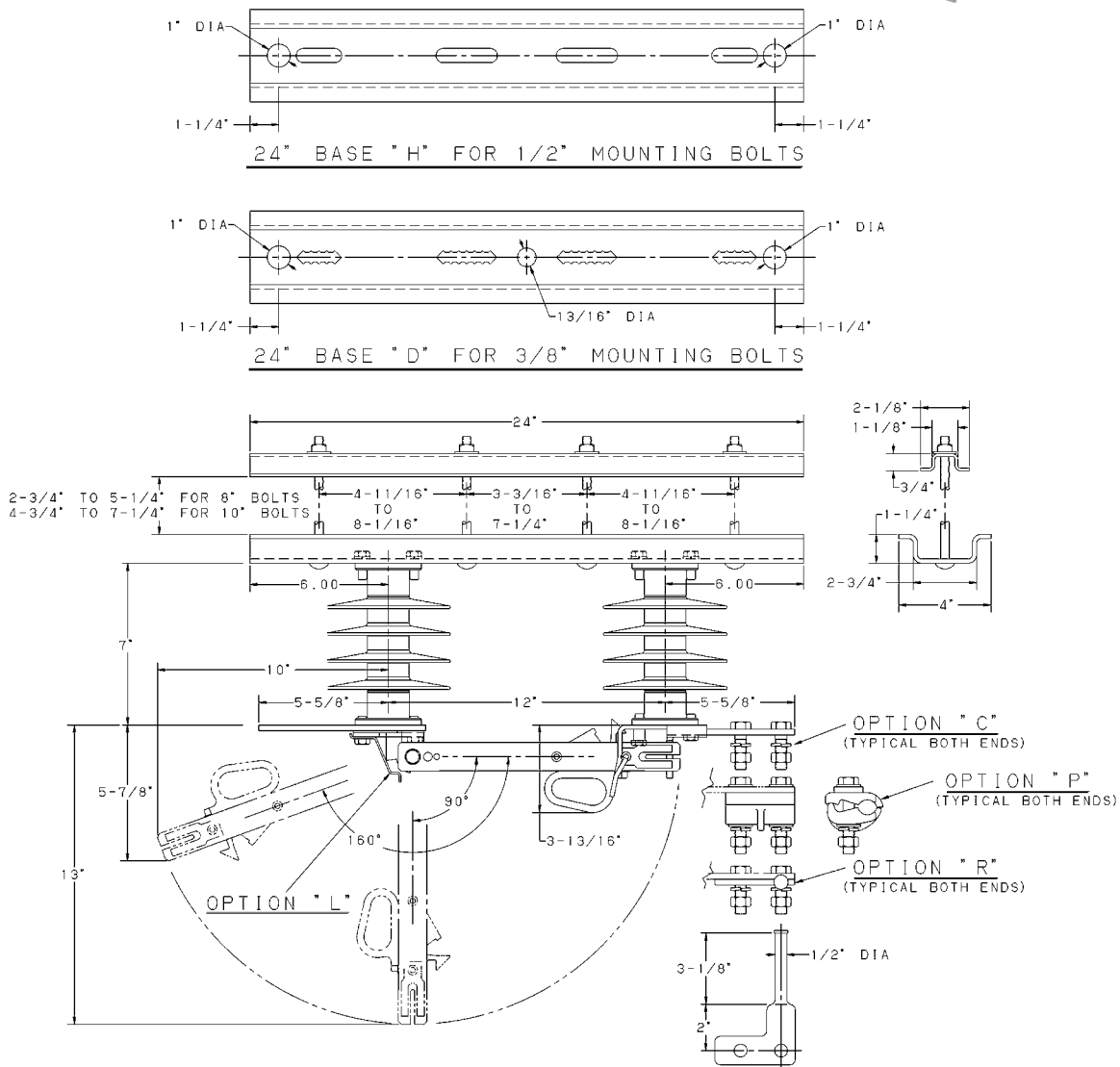

**DISTRIBUTION CLASS
 M3 SWITCH—DIMENSIONAL DATA**
110kV BIL - 900 Amp
125kV BIL - 600 Amp
150kV BIL - 600 & 900 Amp

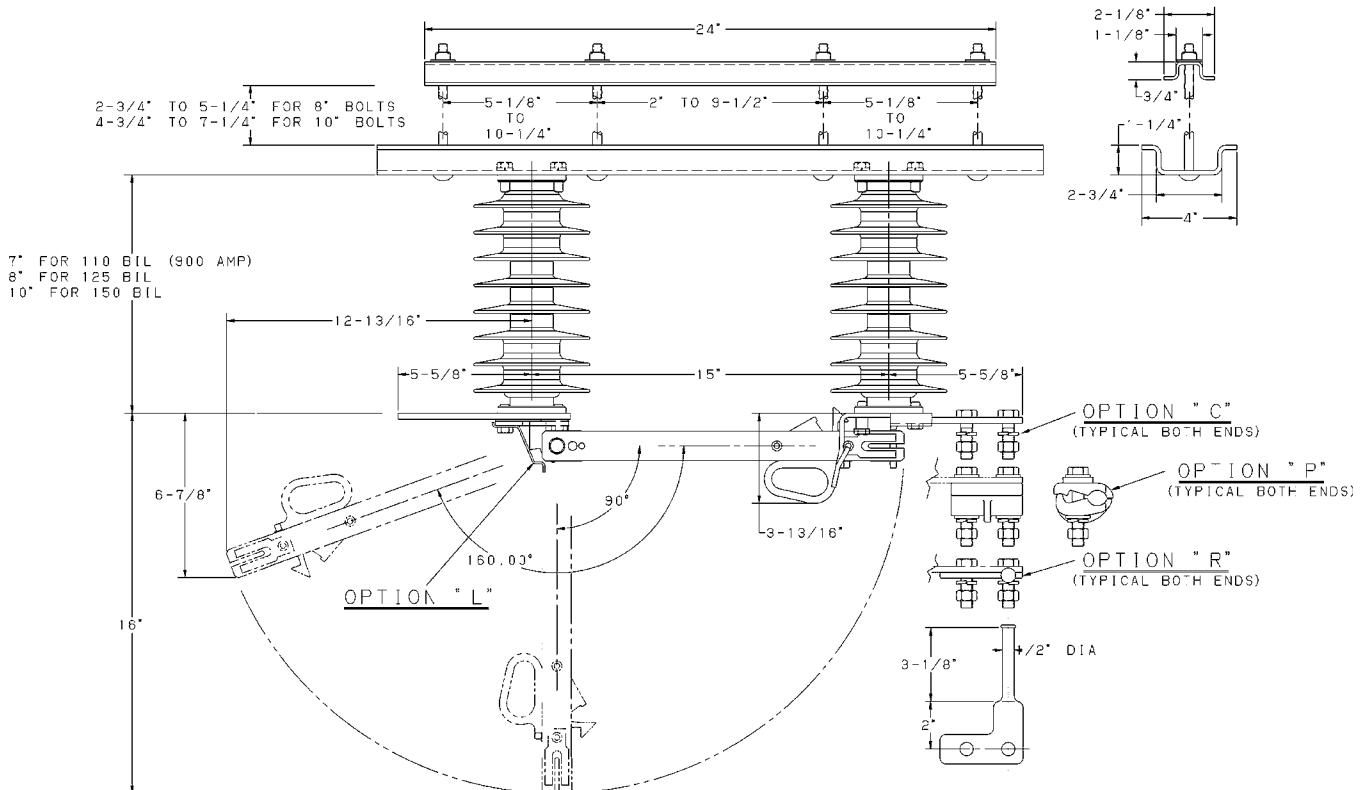
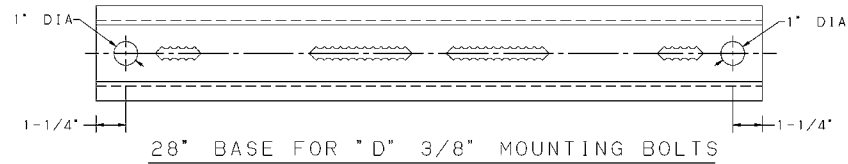
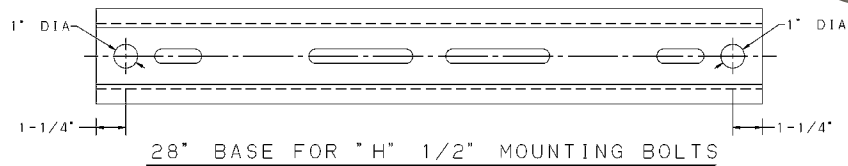

Type M3 Switch DISTRIBUTION CLASS

RUS Listed

Ordering Information

M3**1****2****3****4****5****6****7****BASE**

D = Distribution base, serrated slots with four $\frac{3}{8}$ " x 8"/10" carriage bolts and backstrap

H = Distribution base, smooth slots with four $\frac{1}{2}$ " x 8"/10" carriage bolts and backstrap

RATED CURRENT

6 = 600 AMP

9 = 900 AMP

INSULATION

2 = 15kV 110BIL Porcelain

3 = 25kV 125BIL Porcelain (not available in 900 amp)

4 = 35kV 150BIL Porcelain

6 = 15kV 110BIL Polymer

7 = 25kV 125BIL Polymer (not available in 900 amp)

8 = 35kV 150BIL Polymer

OPTIONS**C = Captive Hardware***

Consists of 4 each: $\frac{1}{2}$ " 13 stainless steel bolts, $\frac{1}{2}$ " flatwasher / lockwasher, $\frac{1}{2}$ " 13 bronze nut

L = Open Position Latch (P8070181P)

Stainless steel latch for holding the blade in the 160° open position

P = Parallel Groove Terminals* (ACT1343 2 per switch)

Two complete connectors and hardware. Accepts #2 - 500 kcmil (Copper or Aluminum)

R = Bypass Studs (P8070166P 2 per switch)

Two copper alloy bypass studs, which can be used for regulator or recloser bypassing

***NOTE:** Captive Hardware and Parallel Groove Terminals **CANNOT** be ordered together.

BOLT LENGTH

A = 10" Length

B = 8" Length



Type M3 Switch STATION CLASS

RUS Listed

Ordering Information
M3 **S** **2** **3** **4** **5** **6**
BASE

S = Station Class Base
Mounted on a steel structure or pole-mounted using an aluminum or steel mounting bracket.

RATED CURRENT

6 = 600 AMP

9 = 900 AMP

INSULATION 3" Bolt Circle

2 = 15kV 110BIL Porcelain

4 = 25kV 150BIL Porcelain

6 = 15kV 110BIL Polymer

OPTIONS
C = Captive Hardware*

Consists of 4 each: 1/2" 13 stainless steel bolts, 1/2" flatwasher / lockwasher, 1/2" 13 bronze nut

**L = Open Position Latch
(P8070181P)**

Stainless steel latch for holding the blade in the 160° open position

**P = Parallel Groove Terminals*
(ACT1343 2 per switch)**

Two complete connectors and hardware. Accepts #2 - 500 kcmil (Copper or Aluminum)

**R = Bypass Studs
(P8070166P 2 per switch)**

Two copper alloy bypass studs, which can be used for regulator or recloser bypassing

***NOTE:** Captive Hardware and Parallel Groove Terminals **CANNOT** be ordered together.



STATION CLASS M3 SWITCH—DIMENSIONAL DATA

Station base: hat-shaped, 6 slots, 20 holes,
integral deadending holes each end
Insulation: Porcelain, 3 in. Bolt Circle, NEMA

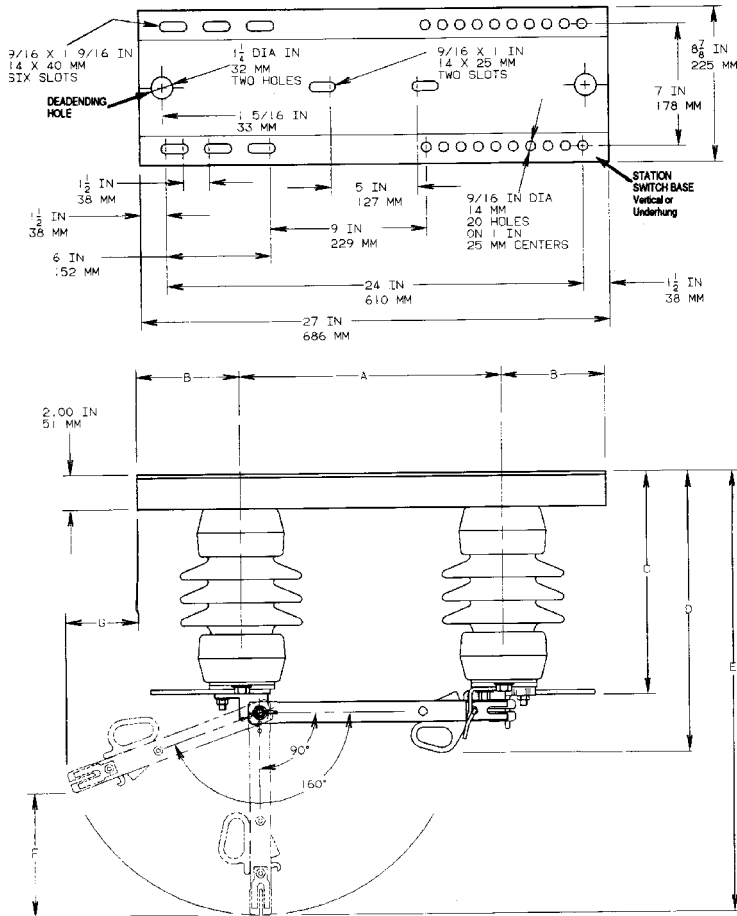

DIMENSIONS (Vertical and Underhung) 27" Base

| BIL | A | | B | | C | | D | | E | | F | | G | |
|--------|--------|-----|--------------------|-----|---------------------|-----|--------|-----|---------------------|-----|--------------------|-----|--------------------|-----|
| | in. | mm | in. | mm | in. | mm | in. | mm | in. | mm | in. | mm | in. | mm |
| 110 kV | 12 | 305 | 7 1/2 | 190 | 12 ^{27/32} | 326 | 14 1/8 | 358 | 24 ^{11/16} | 627 | 7 ^{21/32} | 194 | 3 ^{13/32} | 86 |
| 150 kV | 15 1/8 | 384 | 5 ^{15/16} | 151 | 16 ^{27/32} | 428 | 18 1/8 | 460 | 31 ^{13/16} | 808 | 9 ^{11/16} | 246 | 5 | 127 |

Type M3C Single-Insulator Disconnect Switch

• 15.5 and 27 kV max. • 600 and 900 Amperes

Description and Application

The Type M3C single-insulator disconnect switch is fully rated for 600A or 900A. It is principally used for manual switching of overhead lines on distribution circuits up to 25 kV. The switch is easy to install using a crossarm mounting bracket in the same manner as a cutout.

M3C Switch Components

1. Terminal Pads (All)

Tin-plated high-conductivity copper, NEMA two-hole terminal pad. Parallel Groove connectors (Cat. No. ATC1343) and captive hardware are available as options.

2. Loadbreak Hooks

Hot-dipped galvanized steel hooks are provided as standard.

3. Disconnect Blade

The disconnect blade is of the same construction as that used on the M3 Hookstick Disconnect Switch. The high-conductivity copper blade is silver-plated at all contact areas. Stainless-steel back-up springs are used to maintain efficient current transfer between the stationary contact and the end of the blade. See Catalog page 14B-2 for further description.

4. Insulator

ESP® silicon-alloy rubber, as used for the Type C-Polymer Cutout.

5. Pole Mounting Bracket

A standard pole mounting bracket, NEMA "B" bracket and extended bracket are available.

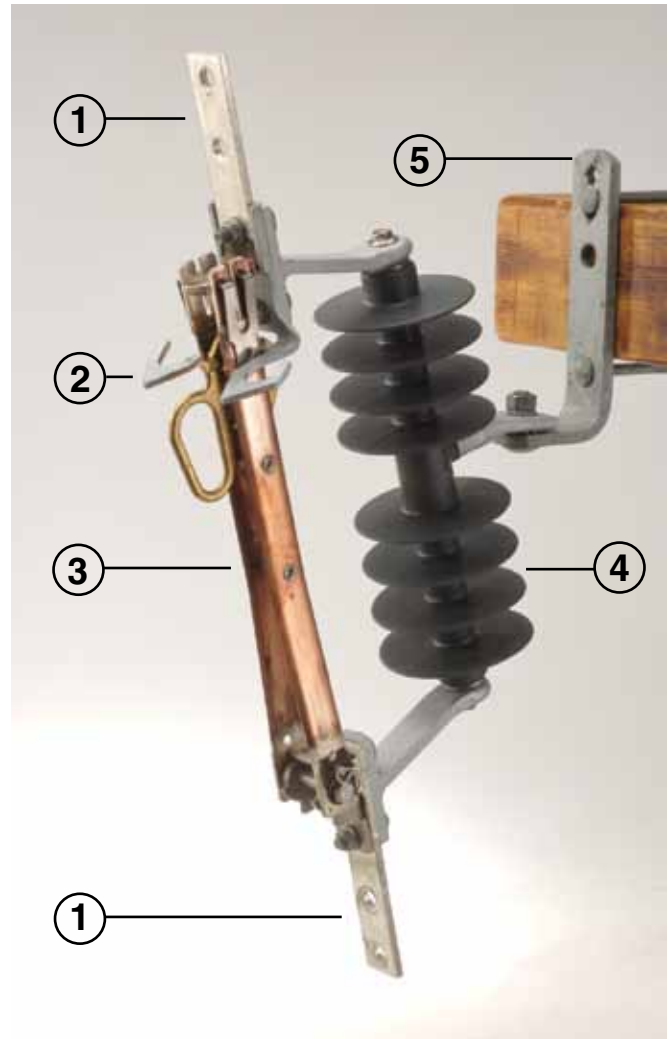

Specifications

- Nominal voltage ratings: 14.4 or 25 kV
- Lightning impulse peak withstand ratings: 110 or 125 kV LIW
- Continuous current rating: 600 or 900 amperes
- Short-time current withstand rating:
 - 600 Amp**
 - 25 kA symmetrical for 1 second
 - 65 kA peak
 - 900 Amp**
 - 25 kA symmetrical for 3 seconds
 - 65 kA peak

...continued on next page >>

Type M3C Single-Insulator Disconnect Switch

• 15.5 and 27 kV max. • 600 and 900 Amperes

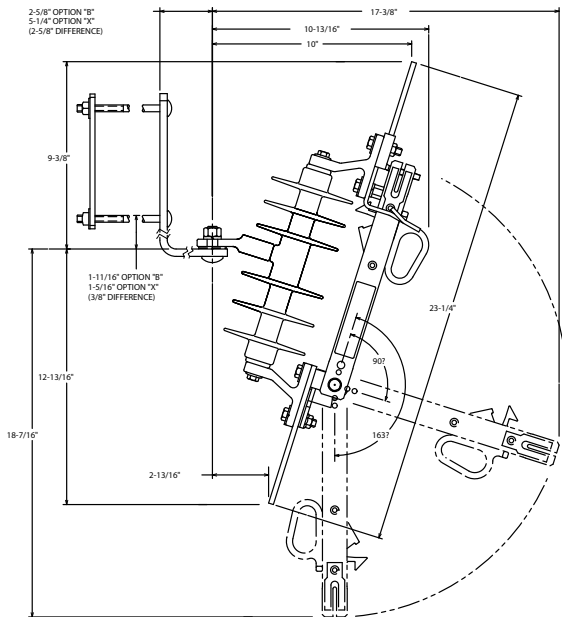

15.5 kV max. (110 kV LIW)

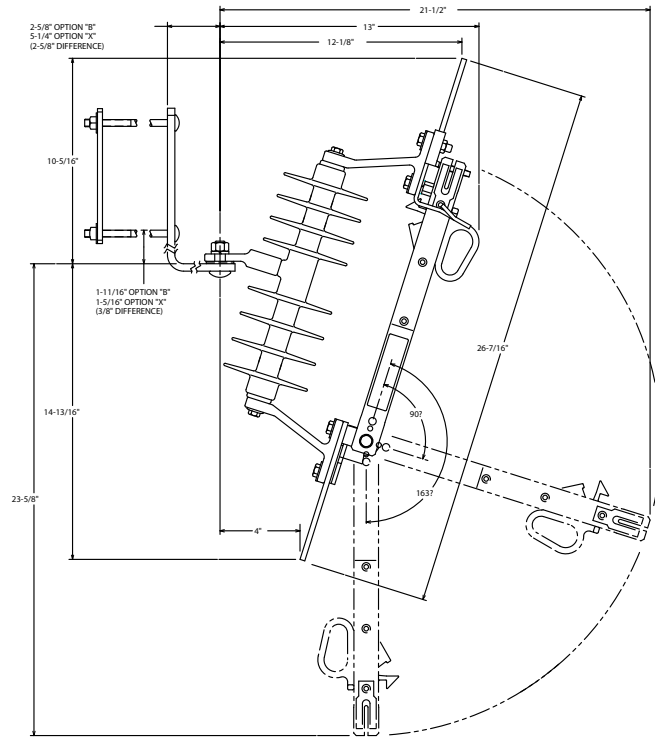

27 kV max. (125 kV LIW)

Ordering Information — CATALOG NUMBER SYSTEM

M 3 C [] [] [] [] [] []

M3C SWITCH

Type M3 Switch live parts
Type C-Polymer Cutout insulator

OPTIONS

- B = NEMA "B" Mounting Bracket**
For crossarm (1½" bolt)
- C = Captive Hardware***
Consists of 4 each: ½" 13 stainless steel bolts, ½" flatwasher / lockwasher, ½" 13 bronze nut
- D = "D" Mounting Bracket**
D-shape bracket for pole mount
- P = Parallel Groove Terminals***
(Cat. No. ACT1343, 2 per switch)
Two complete connectors and hardware. Accepts #2 - 500 kcmil (Copper or Aluminum)
- X = Extended Mounting Bracket**
For crossarm, horizontal section is 2⅝" longer than Type B bracket

SWITCH RATING
15 = 15.5 kV max. (110 kV LIW)
25 = 27 kV max. (125 kV LIW)

CURRENT RATING
6 = 600 Amp
9 = 900 Amp with 25 kV only

***NOTE:** Captive Hardware and Parallel Groove Terminals **CANNOT** be ordered together.

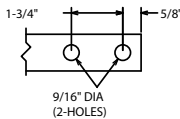

TERMINAL PADS DETAIL

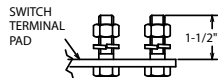

OPTION "C" CAPTIVE HARDWARE
CONSIST OF 4 EACH: 1/2" STAINLESS STEEL BOLTS, LOCKWASHERS, & NUTS

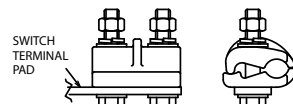

OPTION "P" PARALLEL GROOVE TERMINALS
CONSIST OF 2 EACH: CONNECTORS & HARDWARE FOR #2-500 KCMIL COPPER OR ALUMINUM CONDUCTOR

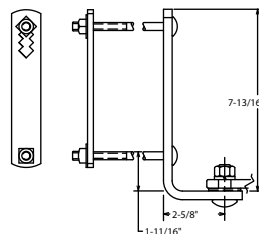

OPTION "B" NEMA "B" BRACKET

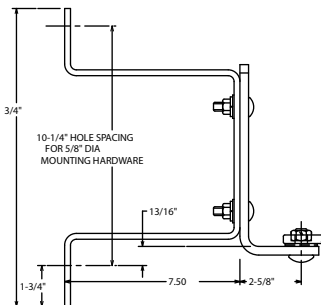

OPTION "D" "D" BRACKET

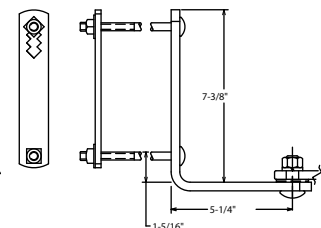

OPTION "X" EXTENDED BRACKET

TYPE ALTD LINE TENSION DISCONNECT SWITCH 200 kV BIL 600 and 900 Amp

Application

The Chance Line Tension Disconnect switches are single-phase hookstick operated for manual switching of de-energized or parallel circuits of overhead lines on an electrical distribution system of 15 through 38kV, 200kV BIL. They are installed directly into the line. Rated for 600 and 900 amperes continuous current, the ALTD may be applied wherever a disconnect switch is desirable for line sectionalizing. A properly rated Type ALTD switch should be selected for each installation with consideration to continuous current, BIL and rated voltage.

The ALTD also can be equipped with a load-breaking interrupter or used with a portable loadbreak tool for load breaking.

Operation

All Chance ALTD disconnect switches include galvanized steel loadbreak hooks for use with a portable loadbreak tool. To open the switch under load, use an approved loadbreak tool or device designated for use with this type of switch.

For easy opening and ice-breaking action, the pull ring activates the latch as a pry-out lever. The hook portion of the contact casting coordinates with the blade latch for positive closure.

Design Features

Lightweight, ESP™ silicon alloy rubber insulators. Chance ALTD switches utilize polymer ESP insulators. The insulator provides 26" leakage distance and BIL rating of 200kV.

Chance has over 20 years of field experience with polymer insulation and over 30 years experience with versatile electrical polymer distribution products.

Low profile. The light weight and narrow profile of the hookstick operated ALTD permits quick in-line mounting in an inverted underhung position.

Copper blade is a rigid H-frame trussed by stainless-steel shoulder pins. Stainless-steel bolts, nuts and compression washers at both ends maintain high pressure contact with bronze hinge and jaw castings. Standard blade opening is 90° or 180° with the stop-pin removed.

Installation. For deadending directly to the switch insulator, the ALTD installs in-line via strain clamps or two bolt full-tension crimp connectors.

Corona ring. An integral full corona ring on castings makes for reduced electrical stress resulting in longer insulator life. The weathershed skirts and leakage distance provide improved resistance to contamination and flashover.

Puncture resistance. The full length dielectric and weathershed thickness give extra dielectric-puncture strength.

Impact strength. High impact strength of the ESP insulator enhances storage, transit and handling properties.

End-fittings. End-fittings make for rugged dependability and strength. The ALTD provides for both a mechanical and electrical connection on a common terminal pad at each end. Terminal Pads are plated aluminum and accept either copper or aluminum NEMA two hole terminal connectors.

**Catalog No. ALTD06200R
RUS Listed**



ALTD with common plated-aluminum terminal pad at each end for mechanical and electrical connections, and ESP insulator.

TYPE ALTD SWITCH with Arc Chute Interrupter

With the addition of the arc chute interrupter, the switch becomes a loadbreak device allowing the ALTD switch to interrupt load currents up to 600 amperes at 15.5kV recovery voltage. Switching of loop circuits up to 600 amps is another capability of the arc chute interrupter. The ALTD switch with arc chute interrupter is also rated for interruption of magnetizing current, line charging current, cable charging current, and capacitor switching.



Catalog No. ALTD06200RL

ALTD with factory mounted load-breaking arc chute interrupter and ESP insulator.

TYPE ALTD SWITCH

Optional Mounting Equipment

• **Stainless-Steel Terminal Bolts (Option B)**

Option includes four each of all stainless-steel terminal fastening hardware: 1/2" -13 x 2" bolts, flat washers, lockwashers and nuts.

• **Extension Link/Adapter (Option C)**

This optional assembly provides a twist-free application by attaching one end of the ALTD switch to a clamp-top insulator.

The adapter portion enables the desired plane of blade movement to be attained regardless of the angle the supporting insulator makes with the pole. Also, blades can be made to operate in parallel planes or in different planes, if line configuration and ease of access make this advantageous. The desired plane of blade action can be set for use on pole-top insulators, on horizontal or 5-degree standoffs and on 15- or 30-degree side-mounted standoffs.

• **Terminal Connectors (Option T)**

Catalog No. ATC1343, fortified cadmium-plated aluminum parallel groove clamp, furnished with galvanized steel bolts and nuts and will accept #2 through 500 kcmil aluminum or copper conductor.

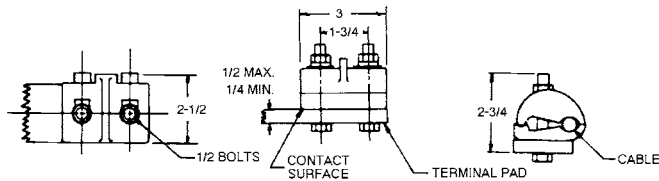

To order these accessories at additional cost, add letter suffix indicated to switch number above. Also add accessory weight to switch weight. Items selected are packed with the switch and carton so marked. Example: For switch with four stainless-steel terminal bolts, extension-link assembly and parallel-groove terminal connectors, order ALTD06200RCT.

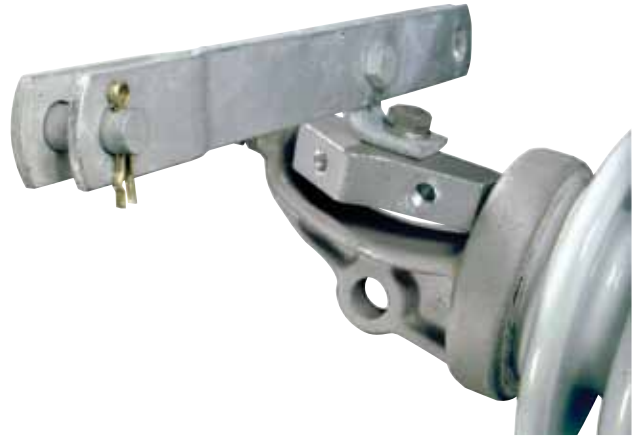

Detail of link mounted on adapter positioned in clamp-top insulator to provide vertical blade opening.

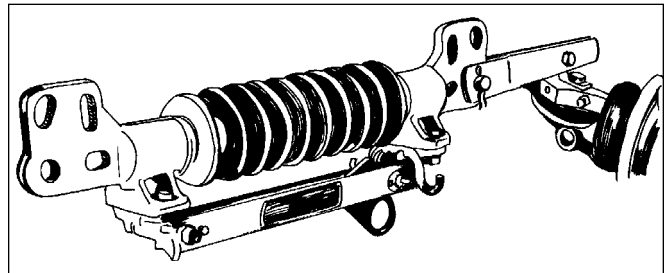
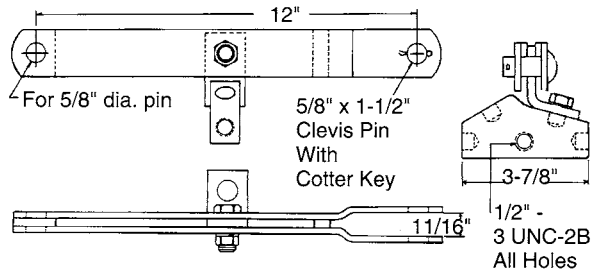

Extension link mounting on 15° standoff for vertical blade opening.

TYPE ALTD SWITCH 600 Amp

ALTD with ESP™ Insulator — RUS Listed

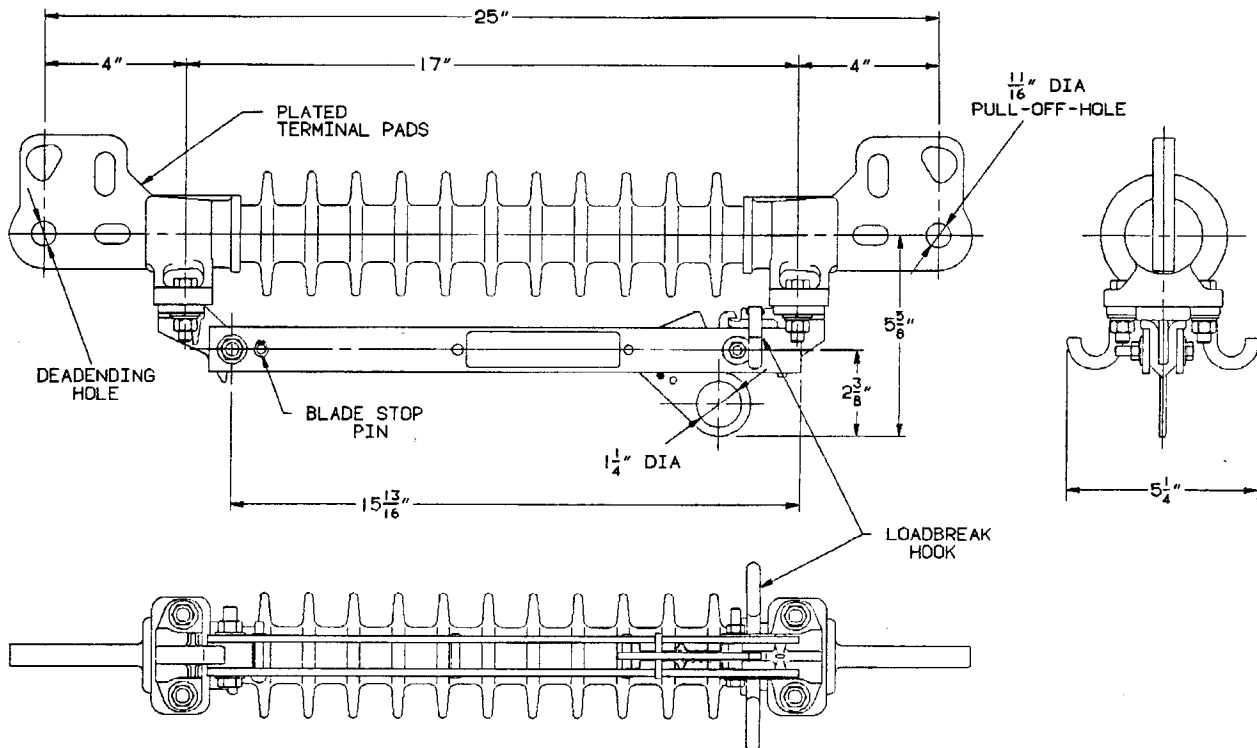

ORDERING INFORMATION

| Catalog Number | BIL kV | CONT. AMPS | MOMENTARY AMPERES | RATED ULTIMATE STRENGTH lb. | WEIGHT | |
|----------------|--------|------------|-------------------|-----------------------------|--------|-----|
| | | | | | lb. | kg. |
| †ALTD06200R | 200 | 600 | 40,000 | 15,000 | 11 | 4.9 |
| *ALTD06200RL | 200 | 600 | 40,000 | 15,000 | 13 | 5.7 |

*Suffix "L" indicates 600-Amp Arc Chute interrupter.

†RUS Listed.

| Suffix | Description | Weight, lb. |
|--------|------------------------------------|-------------------------------|
| B | 4 stainless-steel terminal bolts | ³ / ₄ |
| C | Extension link/angle adapter | 3 ¹ / ₂ |
| T | Terminal Connectors (P-G Type ATC) | 1 |

NOTE: Options B and T cannot be ordered together.

TYPE ALTD SWITCH 900 Amp

ALTD with ESP™ Insulator

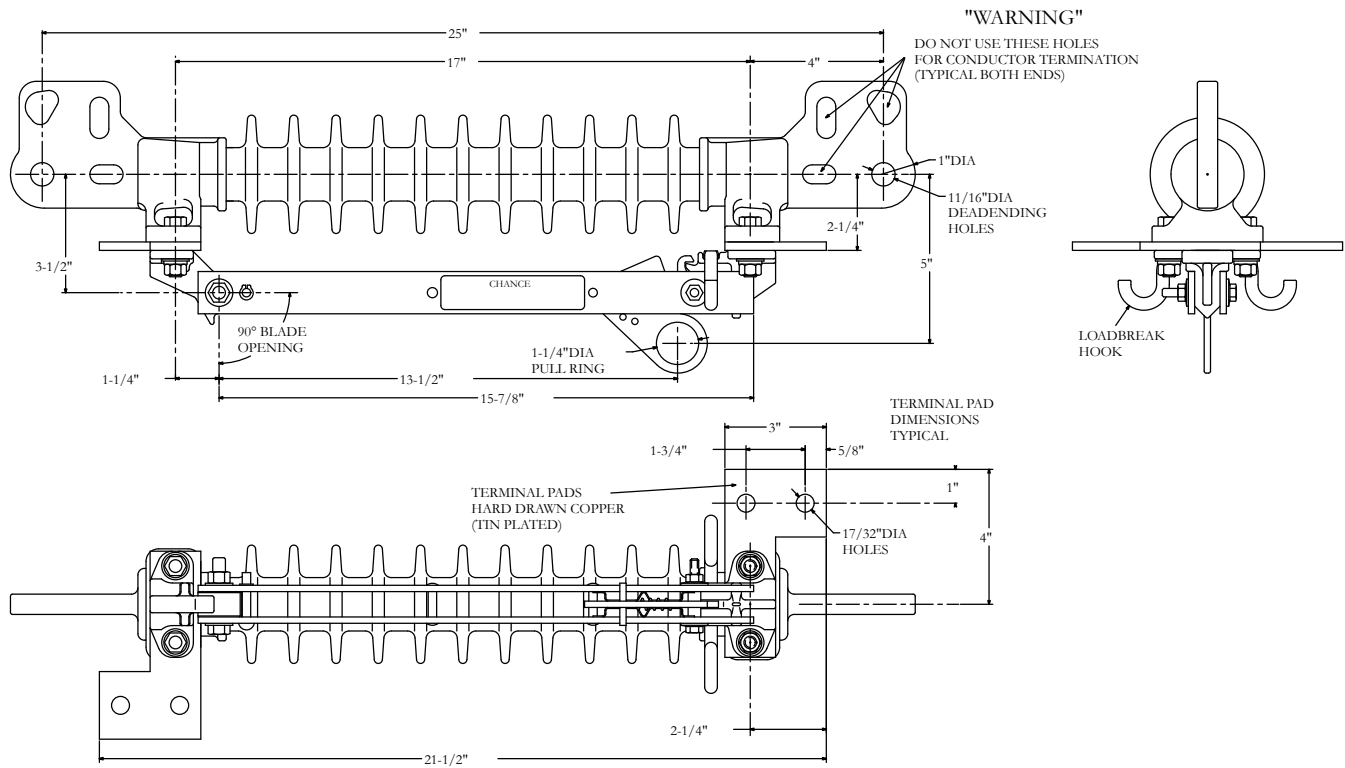

ORDERING INFORMATION

| Catalog Number | BIL kV | CONT. AMPS | MOMENTARY AMPERES | RATED ULTIMATE STRENGTH lb. | WEIGHT | |
|----------------|--------|------------|-------------------|-----------------------------|--------|-----|
| | | | | | lb. | kg. |
| ALTD09200R | 200 | 900 | 40,000 | 15,000 | 12 | 5.3 |

| Suffix | Description | Weight, lb. |
|--------|------------------------------------|-------------|
| B | 4 stainless-steel terminal bolts | 3/4 |
| C | Extension link/angle adapter | 3 1/2 |
| T | Terminal Connectors (P-G Type ATC) | 1 |

NOTE: Options B and T cannot be ordered together.



Type BP3 By-Pass Switch

- 3-Pull • 14.4, 25 & 34.5kV
- Available for 1Ø & 3Ø applications

Principal Application: Recloser Maintenance

By design, the Type BP3 Switch provides an economical means for bypassing and disconnecting a pole-mounted distribution recloser. This permits de-energized periodic maintenance of the recloser without interrupting service. The BP3 Switch accomplishes this by a combination of three disconnect switches mounted on a common base. By operating the blades in proper sequence, the recloser is bypassed and isolated from the distribution system.

Rated at 600 Amps, the BP3 Switch is available in nominal ratings of 14.4kV - 110kV LIW*, 25kV - 125kV or 150kV LIW*, and 34.5kV - 150kV LIW*. All are available with either a right or left opening direction of the by-pass blade.

*LIW = Lightning Impulse Withstand

Operation

Figures below illustrate the BP3 By-Pass Switch operation.

In normal operation, the by-pass switchblade is open and the two disconnect blades are closed, allowing the recloser to be in the circuit.

When recloser maintenance, testing, repair or removal is required, first close the by-pass blade to provide a parallel current path. Then open the recloser's internal contacts. And last, open both disconnect blades of the by-pass switch.

In this way, service continuity is maintained and the recloser is isolated from the line. To put the recloser back in service, the switch operating procedure is reversed.



Back Strap
Mounting
and
Pole
Mounting
variations
available

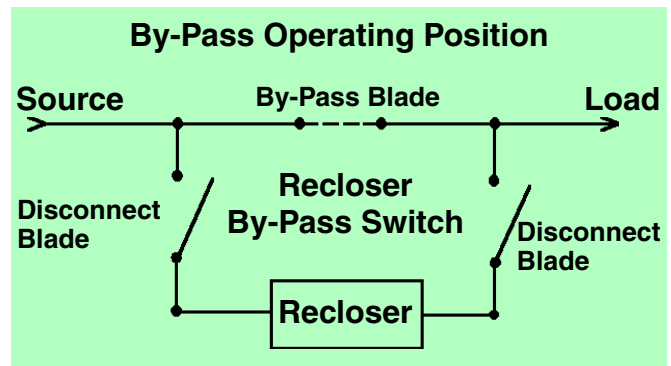
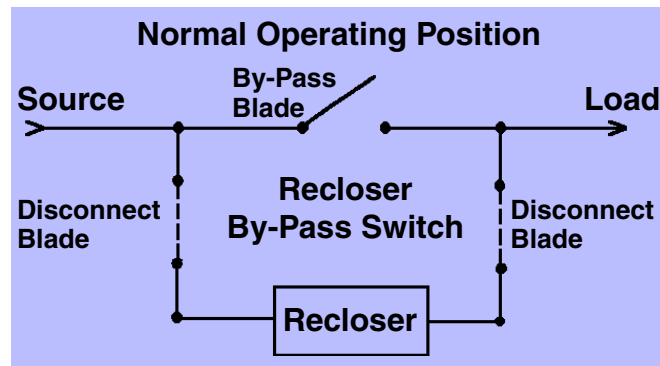

Performance Specifications

- 600 Amps Continuous • 65 kA Peak Withstand

| Max. Design, kV | Lightning Impulse Withstand Rating, kV | Leakage Distance, in. | Weight, lb. |
|-----------------|--|-----------------------|-------------|
| 17.1 | 110 | 17.2 | 56 |
| 29 | 125 | 21.9 | 62 |
| 29 | 150 | 28.2 | 65 |
| 38 | 150 | 28.2 | 65 |

Type BP3 By-Pass Switch

BP3 Switch Components

1. Terminal Pads (All)

Tin-plated high conductivity copper, NEMA two-hole terminal pad. Parallel Groove connectors (ATC1343) and captive hardware are available as options.

2. Loadbreak Hooks

Hot dipped galvanized steel hooks. To allow use of portable loadbreak tool. Provided on by-pass blade only.

3. By-Pass and Disconnect Blades

The by-pass and disconnect blades are of the same construction as those used on the M3 Hookstick Disconnect Switch. They are high conductivity copper blades, silver-plated at all contact areas. Stainless-steel back-up springs are used to maintain efficient current transfer between the stationary contact and the end of the blade. The by-pass blade is available in either right or left opening configurations (hinge on right or left). See Catalog page 14B-2 for further description.

4. Angled Terminal Pads

Angled construction allows for easier connection to a recloser while maintaining maximum pole clearance.

5. Insulators

ESP[™] silicon alloy rubber, 2.25-inch bolt circle insulators. See Catalog page 14B-3 for further description.

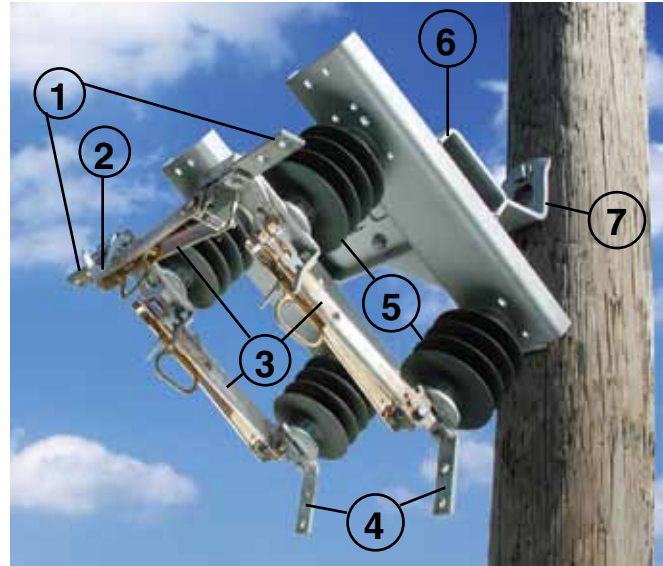

6. Switch Base

Welded-construction galvanized steel base provides maximum rigidity to maintain consistent switch alignment for positive blade operation.

7. Pole Mounting Bracket

Single-piece galvanized steel mounting bracket facilitates ease of installation. A backstrap mounting option also is available.

Feature —

- ESP[™] Silicon Alloy Rubber 2.25 in. Bolt-Circle Insulators
- Fully-welded mounting base
- Angled Terminal Pads
- Utilizes live parts from M3 switches

Advantage —

- Time proven insulator material provides maximum leakage distance and minimizes weight, up to 25% lighter than competitive designs
- Maximum rigidity, eliminates possibility of misalignment compared to bolt-together designs
- Maintains switch alignment for smooth, positive blade operation
- Facilitates connection to recloser with maximum pole clearance
- Time proven design provides reliable service under anticipated service conditions

Switch Variations

1. Right or Left By-Pass Blade Opening (BP3R or BP3L)
Right or left by-pass blade opening may be specified. A right opening by-pass blade opens to the right of the operator when standing in front of the switch. A left opening by-pass blade opens to the left. Illustrations here show only Right by-pass switch blade opening. Left by-pass switch blade opening will be opposite as shown but does not change installation or operation procedures.

2. Switch Mounting — Three options available are:

- **No Mounting Bracket (No option letter in Cat. No.)**
Provides holes and slots in the switch base for direct base to a vertical structure mounting without the use of a back strap or pole mounting bracket. The structure must be drilled to match the base mounting holes or slots. The user supplies the mounting hardware.
- **Back Strap (Option B)**
Provides a galvanized steel back strap and hardware for vertical structural applications. Mounting hardware supplied consists of two each 1/2"-diameter by 8" long and 10" long carriage bolts with square nuts and flat washers.

• **Pole Mounting Bracket (Option M)**

Provides a galvanized steel bracket for wood pole mounting and hardware to attach the switch to the bracket. The user supplies the bracket-to-pole hardware. (If the utility pole is other than a wood pole, contact your factory representative.)

3. Terminal Connectors — Three options available are:

- **No Terminal Hardware (No option letter in Cat. No.)**
The user supplies the terminal connectors and mounting hardware.
- **Captive Hardware (Option C)**
Provides 1/2" diameter by 1 3/4" long stainless bolt secured into each terminal pad hole. Each bolt is supplied with a hex nut and lock washer. Terminal connectors supplied by the user.
- **Terminal Connectors (Option P)**
Four fortified cadmium plated aluminum parallel groove terminal connectors (ATC1343) with terminal pad mounting hardware supplied. The connectors accommodate conductor sizes ranging from No 2 solid copper through 500 MCM copper or aluminum.



For Three-Phase order information, see page 14B-18.

Type BP3 By-Pass Switch Single-Phase Ordering Information

**Ordering Information
Catalog No. System**

BP3

R = Right opening

L = Left opening

INSULATION

1 = 14.4kV, 110kV LIW*
(17.1kV max. design,
17.2" leakage distance)

2 = 25kV, 125kV LIW*
(29kV max. design,
21.9" leakage distance)

3 = 25kV, 150kV LIW*
(29kV max. design,
28.2" leakage distance)

4 = 34.5kV, 150kV LIW*
(38kV max. design,
28.2" leakage distance)

*LIW = Lightning Impulse Withstand

OPTIONS

B = Mounting, Back Strap
(not available with Option M)

C = Captive Terminal Hardware
(not available with Option P)

M = Mounting, Pole Bracket
(not available with Option B)

P = Terminal Connectors
(ATC1343, 4 per switch)
(not available with Option C)

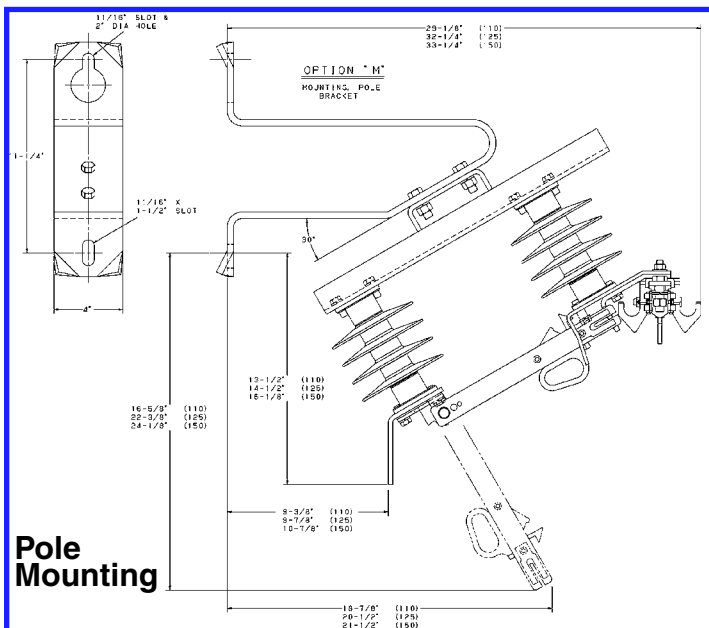
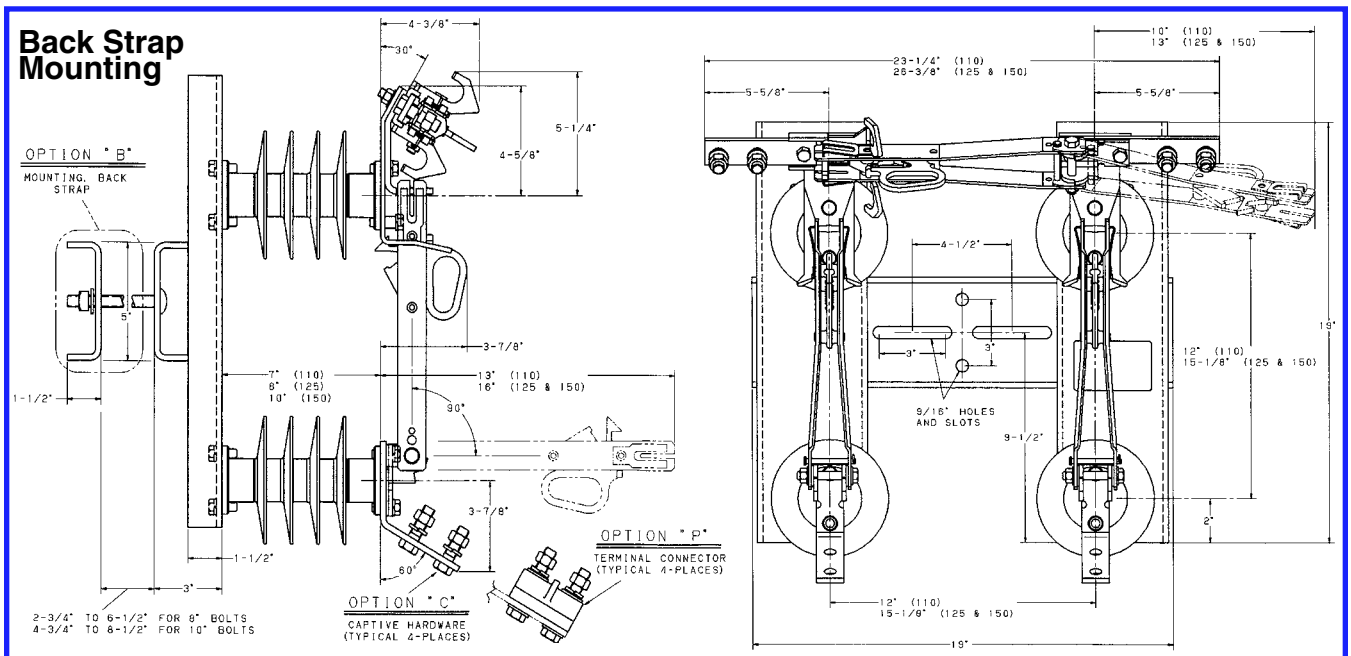

Type BP3 By-Pass Switch

For Single-Phase ordering information, see page 14B-17.

Three-Phase Ordering Information

The BP3 Switch for three-phase application is also available. The three-phase BP3 ships pre-assembled on a crossarm, the complete assembly ready for easy installation at the site.



- Available for any BP3 Switch rating
- Choose Steel or Fiberglass crossarm
- Variety of connector terminal options

To get a Catalog Number assigned and request a Price Quotation:

1. Select BP3 maximum kV rating from table at the bottom of Catalog page 14B-15.
2. Choose the crossarm material, either steel or fiberglass. Standard Length is 8' 5".
3. Specify connectors. (Drawing below and photo above show CCLS-814-C connectors, popular for providing a 90-degree jumper mount.)

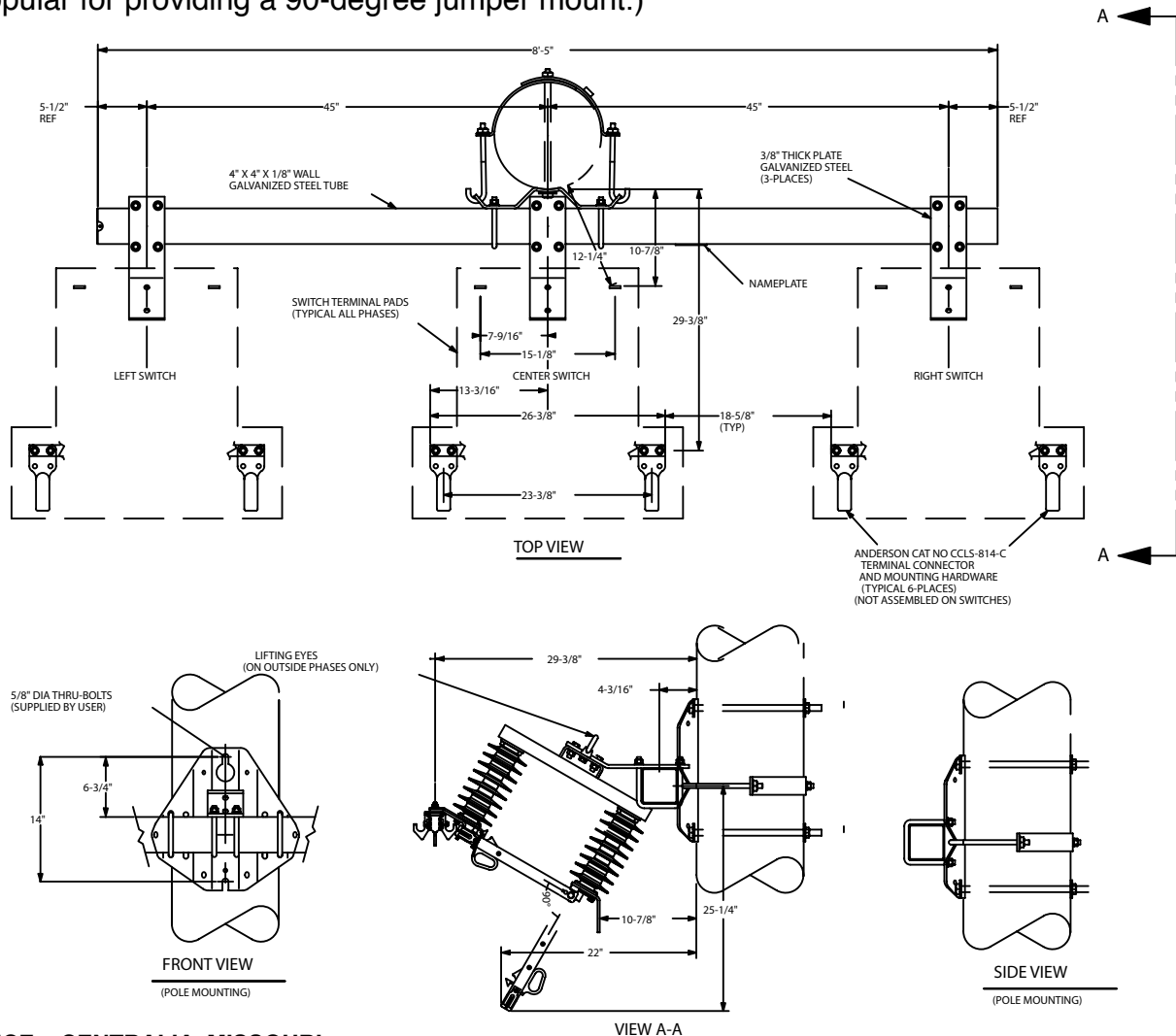

Type BPF Station Class Fused By-Pass Switch for Substation Mounting

• 15 & 27kV • 100 & 200 Amp Fusing

Description and Application

The Type BPF By-Pass Switch is used to bypass and isolate substation reclosers for routine maintenance and repair. The switch usually is applied in combination with a separately mounted M3S companion disconnect switch.

The BPF By-Pass Switch consists of a 600 Amp loadbreak disconnect switch in series with a Type C cutout fuse holder, which provides protection to the circuit while the recloser is out of service. Both devices are mounted on a common mounting channel for ease of installation. Both 100 Amp and 200 Amp fuse holders are available to fit specific installation requirements.

The BPF Switch is available in ratings of 15kV - 110kV LIW* and 27kV - 150kV LIW* with either 100 Amp or 200 Amp fusing. The fuse mounting can be either on the right- or left-hand side of the switch.

*LIW = Lightning Impulse Withstand

Operation

Operation of the Type BPF Bypass Switch is shown in the figure below (shown with an M3S companion disconnect switch). In normal operation the fuse holder is disconnected and the circuit recloser provides circuit protection. To bypass

the recloser for repair, maintenance, etc., the cutout fuse holder with appropriate fusing is installed in the bypass disconnect and closed and the series disconnect switch blade is opened to isolate the recloser. The M3S companion disconnect switch is opened last to completely isolate the recloser from the circuit.

To restore service, the recloser should be closed. The M3S companion disconnect switch is closed followed by the disconnect blade on the BPF Bypass Switch. The fuse holder is then opened and removed.

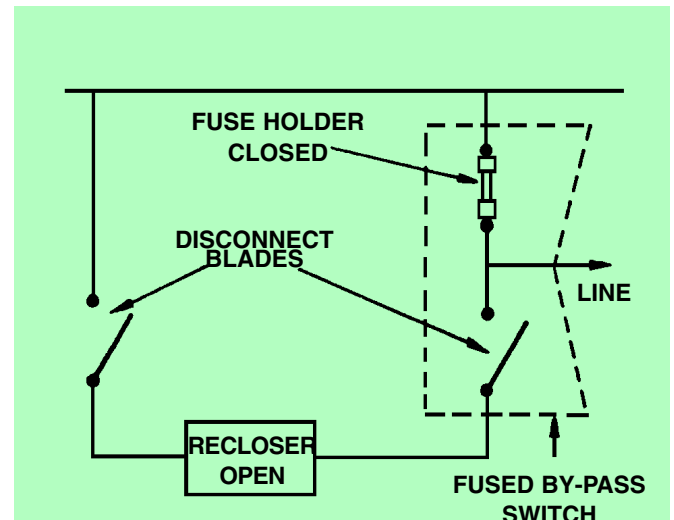
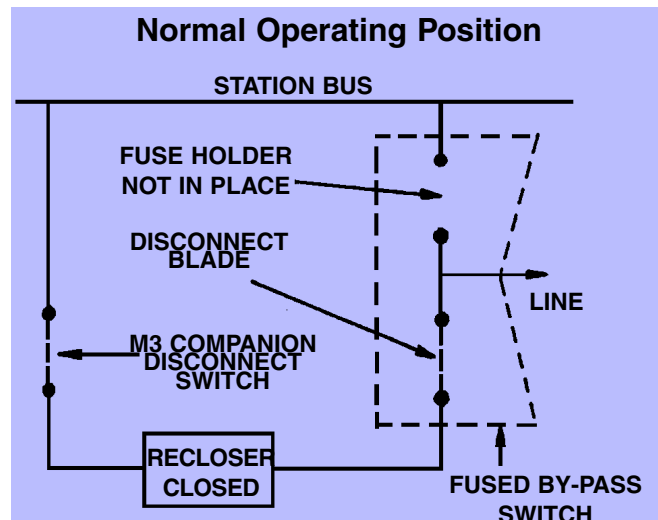
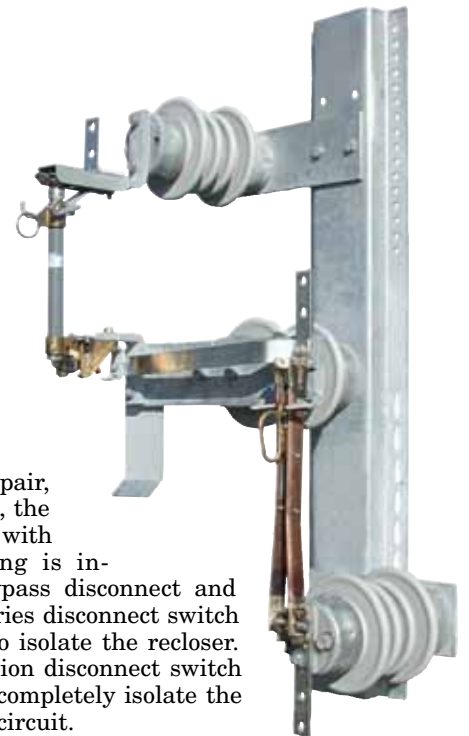

Performance Specifications

• 600 Amps Continuous • 65 kA Peak Withstand

| Max. Design, kV | Fuse, Cont. Amps | Lightning Impulse Withstand Rating, kV | Interrupting Rating, kA asym. | 3 in. Bolt Circle Insulator TR No. | Weight, lb. |
|-----------------|------------------|--|-------------------------------|------------------------------------|-------------|
| 15 | 100 | 110 | 10.0 | 205 | 125 |
| 15 | 200 | 110 | 12.0 | 205 | 125 |
| 27 | 100 | 150 | 8.0 | 208 | 140 |
| 27 | 200 | 150 | 10.0 | 208 | 140 |

Type BPF By-Pass Combination Switch

BP3 Switch Components

1. Terminal Pads (All)

Tin-plated high-conductivity copper, NEMA two-hole terminal pad. Parallel Groove connectors (Cat. No. ATC1343) and captive hardware are available as options.

2. Loadbreak Hooks

Hot-dipped galvanized steel hooks are provided as standard on the disconnect blade and fuse mounting.

3. Disconnect Blade

The by-pass disconnect blade is of the same construction as that used on the M3 Hookstick Disconnect Switch. They are high-conductivity copper blades, silver-plated at all contact areas. Stainless-steel back-up springs are used to maintain efficient current transfer between the stationary contact and the end of the blade. See Catalog Section 14B for further description.

4. Type C Cutout Fuse Holder

The same fuse holder used in Type C Cutouts, with a wealth of field operating history. Available in either 100 Amp or 200 Amp and mounting on the right- or left-hand side of the switch assembly.

5. Insulators

Insulators are ANSI/NEMA 3-inch bolt circle TR 205 or 208.

6. Mounting Base

Formed galvanized-steel base provides maximum rigidity and is designed for substation structure mounting.

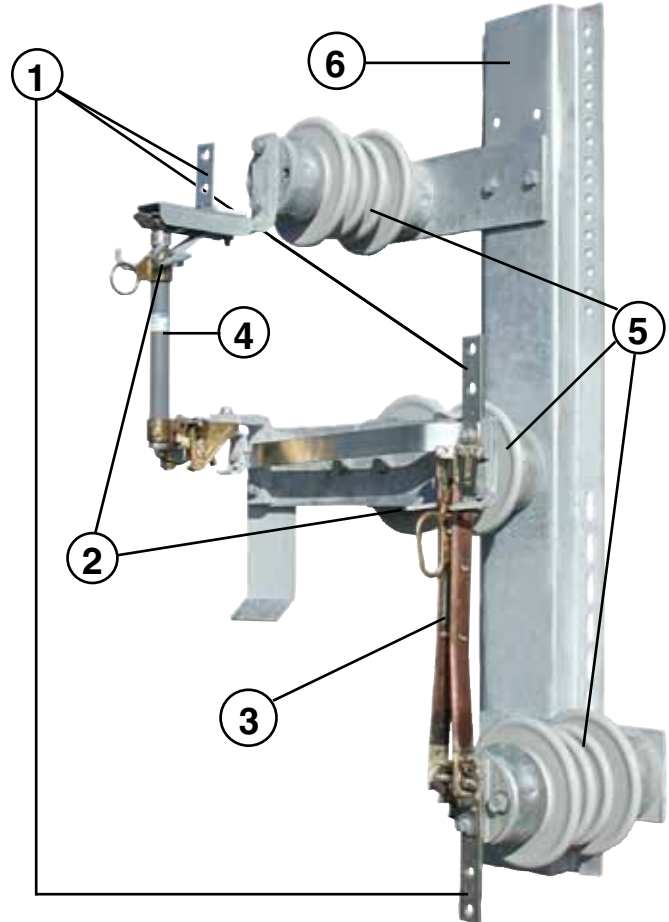

Feature —

- M3 Switch blades and stationary contact
- Type C Cutout fuse holder
- Formed galvanized-steel mounting base

Advantage —

- Utilizes proven current-carrying components from the M3 Switch
- Field-proven performance from the Type C Cutout
- Provides maximum strength and rigidity

Type BPF By-Pass Combination Switch

Ordering Information
Catalog No. System

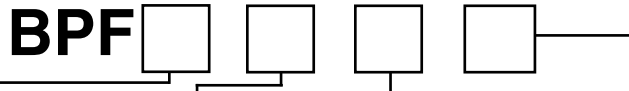

| Fuse Alignment | Voltage, Insulation | Fusing | Options |
|------------------------|---------------------|--------------------|---|
| R = Fuse on Right side | 1 = 15kV, 110kV LIW | 1 = 100Amp Type C | C = Captive Terminal Hardware (not available with Option P) |
| L = Fuse on Left side | 2 = 27kV, 150kV LIW | 2 = 200 Amp Type C | P = Terminal Connectors (ATC1343, 3 per switch) (not available with Option C) |

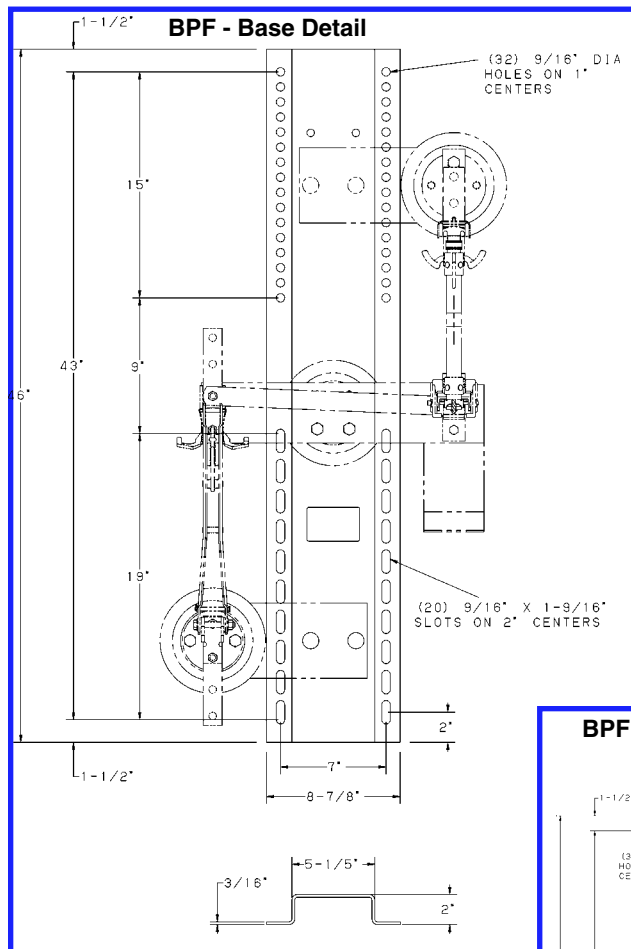

| Replacement Fuse Holders | | |
|--------------------------|--------|-------------|
| Ratings | | Catalog No. |
| 15kV | 100Amp | T710112T |
| 15kV | 200Amp | T710143T |
| 27kV | 100Amp | T710311T |
| 27kV | 200Amp | T710342T |

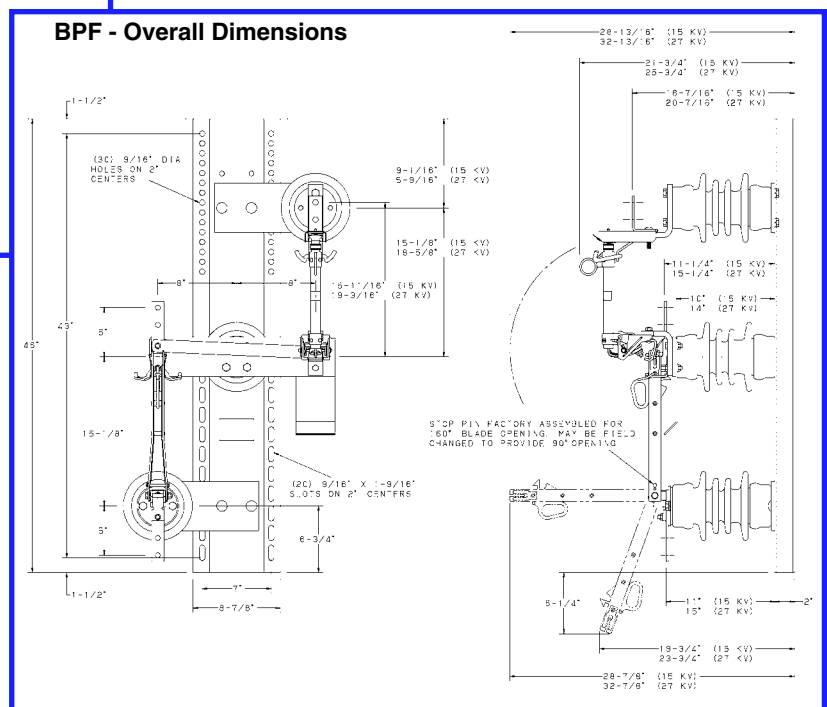

Type BPR Regulator By-Pass Switch for Distribution or Substation Mounting

• 15.5, 27 & 38kV • Single-Pull Operation

Designed for Applications

By design, the Type BPR Switch allows undisturbed continuity of service and provides an economic means for bypassing and disconnecting a distribution or substation voltage regulator for maintenance. It is designed for use with all voltage regulators that can be set on neutral for the switching operation. This includes all single- and three-phase regulators except three-phase induction regulators. The BPR Switch is automatically sequenced to bypass the voltage regulator with a single pull operation, without interrupting service to the system. That is, the voltage regulator is always bypassed in proper sequence without any specific operation actions by the operator.

The **BPRD Switch** for **Distribution** voltage regulators is applied where isolation from the system is required to

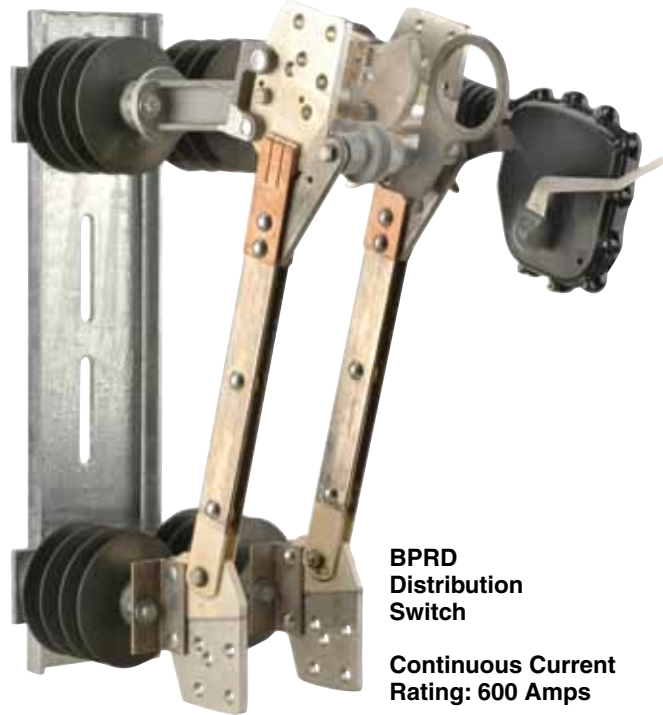

**BPRD
Distribution
Switch**

**Continuous Current
Rating: 600 Amps**

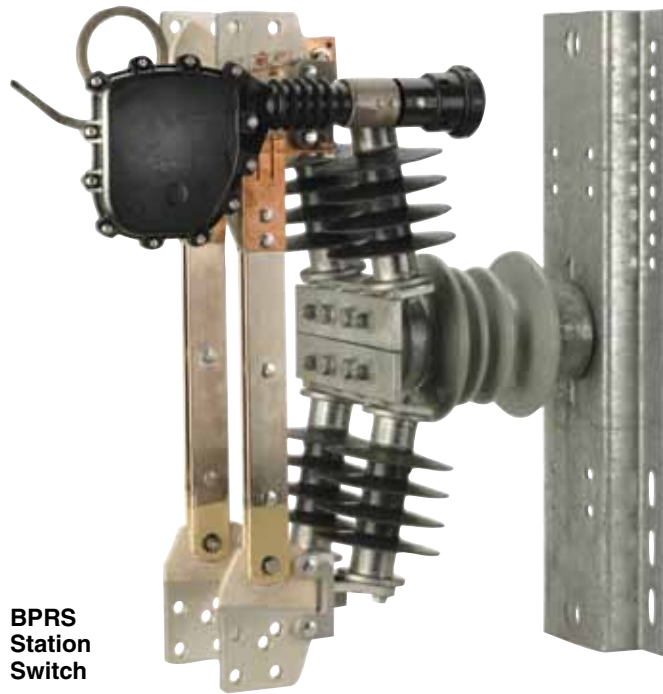

**BPRS
Station
Switch**

perform periodic maintenance. A 600-Amp rated switch, the Type BPRD is available in system application ratings of 15.5kV - 110kV LIW*, 27kV - 150kV LIW*, and 38kV - 150kV LIW* (for use on grounded-wye systems). The BPRD switch utilizes a mounting base designed for crossarms, poles and other distribution applications.

The **BPRS Switch** for **Station Class** voltage regulators is applied where isolation from the system is required to perform periodic maintenance. Available in 600 and 1200-Amp ratings switch, the Type BPRS is available in voltage application ratings of 15.5kV - 110kV LIW* and 27/38kV - 200kV LIW* (can be used on grounded-wye systems). The BPRS switch utilizes a mounting base designed for substation structures.

**LIW = Lightning Impulse Withstand*

Continuous Current Ratings: 600 Amps and 1200 Amps

Performance Specifications

| Application, Catalog No. | Design kV, Nom./Max. | Lightning Impulse Withstand, kV | Continuous Current Rating, Amperes | Peak Withstand, Peak Amperes | Short Time Withstand, Amps | Weight, lb. |
|--------------------------|--------------------------|---------------------------------|------------------------------------|------------------------------|----------------------------|-------------|
| Distribution, BPRD06 | 14.4/17.1 | 110 | 600 | 65,000 | 25,000 | 75 |
| | 25.0/29.0 | 150 | 600 | 65,000 | 25,000 | 80 |
| | 34.5/38.0 [†] | 150 | 600 | 65,000 | 25,000 | 80 |
| Station, BPRS06 | 14.4/17.1 | 110 | 600 | 65,000 | 25,000 | 90 |
| | 27.0/29.0 | 200 | 600 | 65,000 | 25,000 | 95 |
| | & 34.5/38.0 [†] | | | | | |
| Station, BPRS12 | 14.4/17.1 | 110 | 1200 | 99,000 | 40,000 | 90 |
| | 27.0/29.0 | 200 | 1200 | 99,000 | 40,000 | 95 |
| | & 34.5/38.0 [†] | | | | | |

[†]38.0kV grounded-wye application only

Type BPR Regulator By-Pass Switch

Automatic Sequenced Operation

Both the Type BPRD and BPRS are single-pull sequenced switches. A **single pull on the pull ring on opening** performs four switching operations (A, B, C, D) in proper sequence as shown.

During the closing operation, the automatic sequence is reversed. The enforced sequence operation minimizes the

possibility of operator error. Instructions included with the BPR switch outline how to properly release the Bypass blade latch, rotate the Bypass blade and check operating sequence prior to operating the switch for the first time.

*Should the Bypass blade become out-of-sequence, its latching mechanism interferes to prohibit the Disconnect blades from closing.

Normal Operating Position

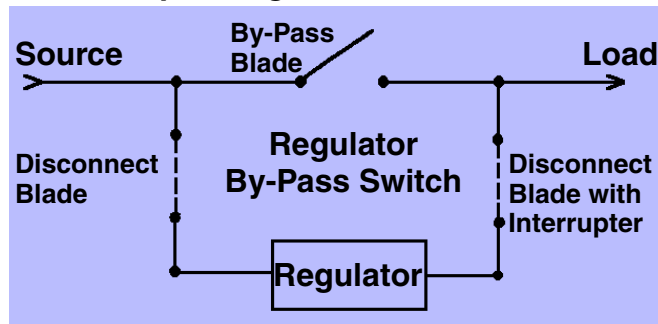

By-pass blade is open and disconnect blades are closed.

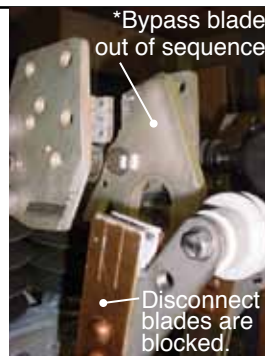
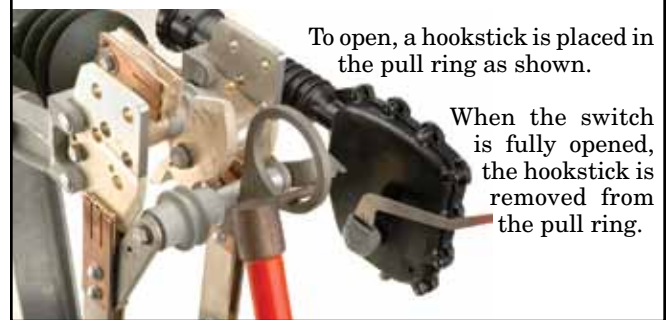

A. Bypass blade closes. *When closing the switch, if the Bypass blade is out of sequence for any reason, the Disconnect blades are prevented from closing.



B. Source disconnect blade opens.

By-Pass Operating Position

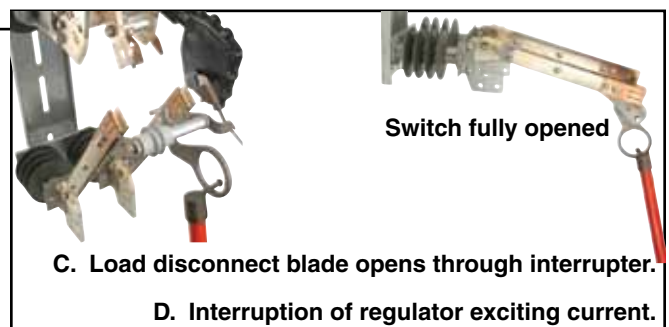
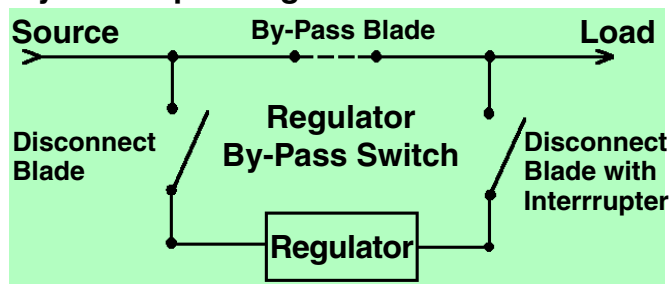

Feature —

- Distribution base design and resultant angled switch mounting
- Versatile terminal pad design
- BPRS is the only single-pull 1200-Amp regulator by-pass switch available.
- ESP® silicone alloy rubber insulators

Advantage —

- Mounts without drilling holes or additional mounting brackets. Angled mounting facilitates opening and closing operation
- Allows use of NEMA 2-hole or 4-hole terminals and training of incoming conductors for the most desirable connections
- Provides the reliability of single-pull operation, plus reduced size and weight for a 1200-Amp switch
- Time-proven technology for long-term performance and light weight

Type BPR Regulator By-Pass Switch

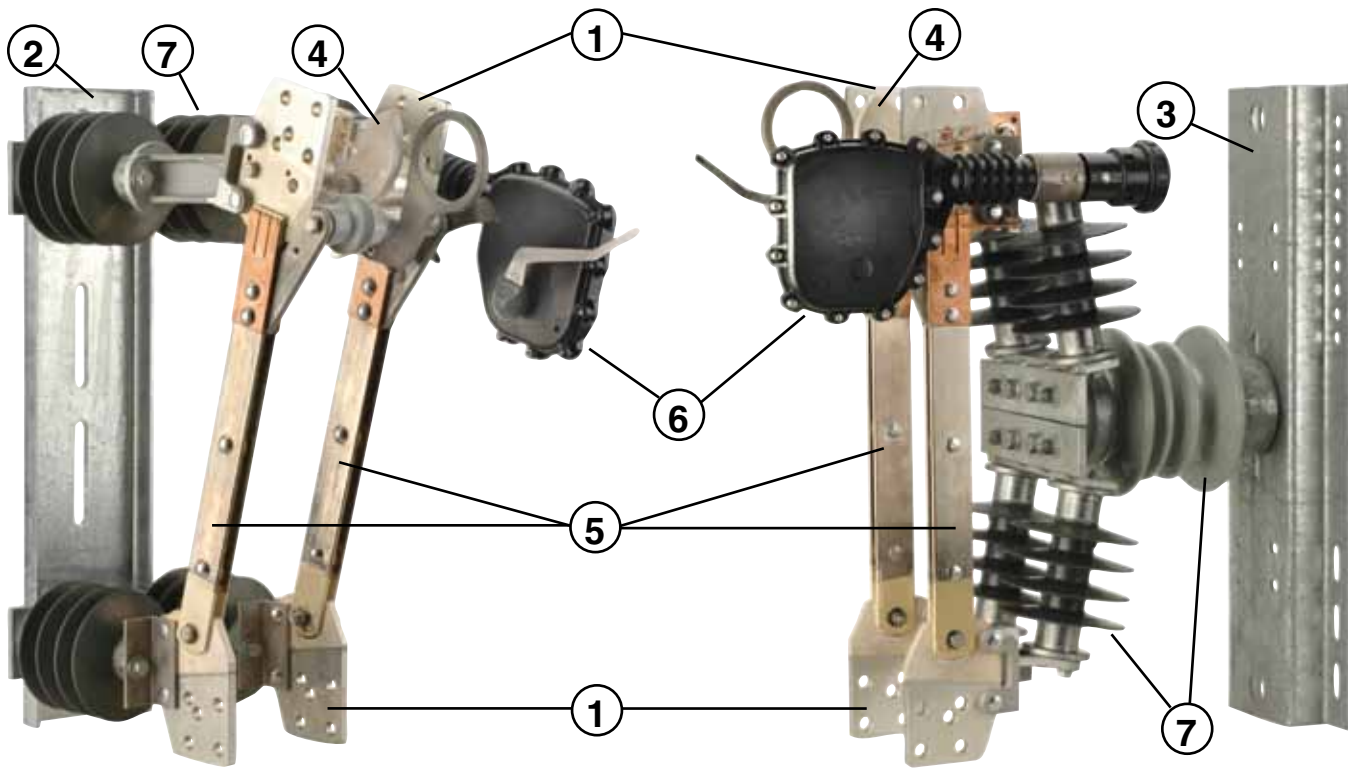

BPRD Distribution Switch

BPRS Station Switch

Components of the Type BPR Switch

1. Terminal Pads

High-conductivity tin-plated copper terminal pad accommodates NEMA two-hole or four-hole configurations. To permit “training” incoming conductors for the most convenient connections, the terminal pad design provides extra bolt holes.

2. Mounting Base - Type BPRD Distribution Switch

Versatile galvanized-steel base design permits mounting on distribution poles as well as single or double crossarms. Angled mounting of the base places the switch at 15° for easy opening and closing operation.

3. Mounting Base - Type BPRS Station Switch

Galvanized-steel base design permits convenient mounting on substation structures.

4. By-Pass Blade

The by-pass blade is silver-plated high-conductivity copper. It is mechanically connected to the disconnect blades to operate in proper sequence.

5. Disconnect Blades

The disconnect blades are high-conductivity copper, silver-plated at all contact areas. These blades are mechanically connected to the by-pass blade to operate in proper sequence.

6. Interrupter

Interrupter technology will properly interrupt all expected regulator exciting currents during by-pass operation.

7. Insulators

ESP[®] silicone alloy rubber, 2.25-inch bolt circle insulators. See Catalog page 14B-3 for further description. Type BPRS switch utilizes a TR-rated station post insulator to meet most substation requirements.

Ordering Information — Catalog No. System

Distribution Switch - 600 Amp Rating

BPRD06

| Voltage, Insulation | |
|---------------------|---|
| 1 | 14.4kV, 110kV LIW (17.1kV Max.) |
| 2 | 25kV, 150kV LIW (29kV Max.) |
| 3 | 34.5kV, 150kV LIW (38kV Max. grounded-wye only) |

| Optional |
|----------------------------------|
| B = Crossarm Back Strap Assembly |

Station Switch - 600 & 1200 Amp Rating

BPRS

| Continuous Current Rating |
|---------------------------|
| 06 = 600 Amperes |
| 12 = 1200 Amperes |

| Voltage, Insulation | |
|---------------------|--|
| 1 | 14.4kV, 150kV LIW (17.1kV Max.) |
| 2 | 29/38kV, 200kV LIW (38kV Max. grounded-wye only) |

Type BPR Regulator By-Pass Switch

